

Ultimate Performance

Speeds up to **4800**
 Nigiri sushi rice balls / hour

"Superior sushi rice shaping technology that creates the great handmade texture made by professional sushi chefs."

Compact Sushi Machine SSN-JLX-EH



Make Perfect Soft and Fluffy Nigiri Sushi Rice Balls

Creates consistent, high quality nigiri sushi rice balls using our proven technology for accurate measuring for perfect traditional shaped nigiri sushi rice balls without kneading, crushing, or cutting the rice grains.

Easy User Operation

Simple operation using the LCD touch screen panel to adjust speed, softness, weight, and compression. Set user language preference in English, French, German, Spanish, Korean, Chinese, or Japanese.

** Asian region model can be displayed in English, Chinese, Korean, and Japanese languages.*

Integrated Rice Warmer

Keep the sushi rice at the optimal temperature to allow for the output of warm nigiri sushi rice balls.

Choose from Two Different Sized Rice Hoppers

Standard Hopper: Approx. 10kg (22.05lb)

Dimensions

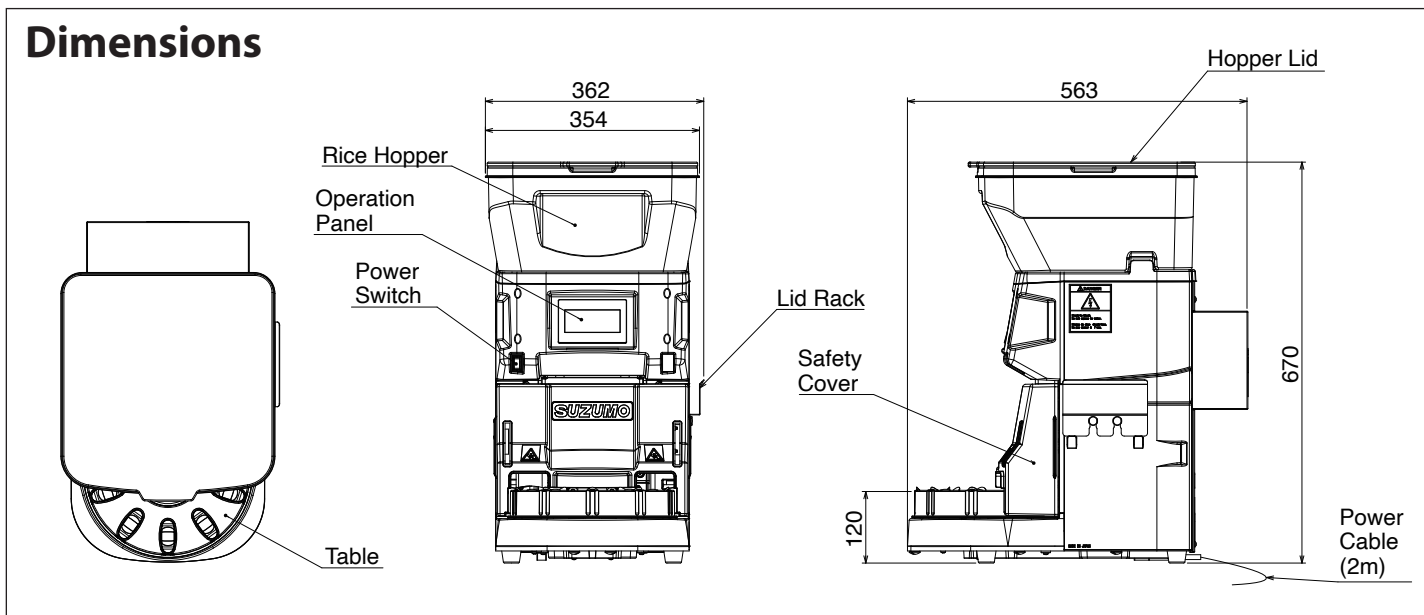

Specification

Model	SSN-JLX-EH (Meets UL/NSF standards)
Capacity	3000, 3600, 4200, 4800 pieces / hour (selectable) * When weight is set at 21-22g (0.74-0.78oz) the maximum capacity may be lower.
Machine Dimensions	Standard hopper: 362W×563D×670H mm (14.25"W×22.17"D×26.38"H) *With lid storage rack and the large-size rice hopper included.
Input	AC 110-120V, 60Hz single phase
Power Consumption	100W
Hopper Capacity	Standard hopper: approx. 10kg (22lb)
Weight per piece	Minimum 12g* (0.43oz) to maximum 22g (0.78oz) * 12g (0.43oz) to 16g (0.56oz) requires different mold unit
Hardness Setting	7 adjustment levels - soft to hard
Machine Weight	Approx. 25kg (55.1lb)
Rice Warming Function	ON/OFF selectable

Features

- Compact design with easy loading of sushi rice into the machine.
- The integrated rice warming function keeps the rice at an optimal temperature for output of the ideal form and texture of the nigiri rice balls.
- Makes consistent and perfect soft and fluffy nigiri sushi rice balls without kneading and crushing of the nigiri sushi rice ball.
- Easy to view and use LCD touch screen display panel allows for quick customization and operation.
- Simple assembly and disassembly. Easy to clean, sanitize, and maintain.

*Design and specification subject to change without notice.

*Please follow the instruction in the operation manual when handling the machine.

*While capacity expresses the machine's performance capabilities, it is predicated upon the machine being operated correctly.

Suzumo Machinery Co., Ltd. Global Business Division

2-23-2, Toyotamakita, Nerima-ku, Tokyo 176-0012, Japan
Tel. +81 3-3993-1407 Fax. +81 3-3993-1756
e-mail overseas@suzumo.co.jp URL <http://www.suzumokikou.com>

< Contact in North America >

Suzumo International Corporation

Head Office : 1815 W. 205th Street, Suite 101 Torrance, CA 90501 U.S.A.
Tel. +1 310-328-0400 Fax. +1 310-328-2700 e-mail sic@suzumokikou.com

East Office : 375 North Street, Unit K, Teterboro, NJ 07608 U.S.A.
Tel. +1 201-568-1900 e-mail sic@suzumokikou.com

< Contact in Singapore >

Suzumo Singapore Corporation Pte. Ltd.

421 Tagore Industrial Avenue #04-11 Tagore 8, Singapore 787805
Tel. +65 6254-2080 Fax. +65 6254 2086 e-mail sales@suzumo-sg.com