



PREPARED WITH THE SKILL OF A JAPANESE SUSHI CHEF

Kubota Automatic Commercial-Use Rice Preparation Equipment



Rice Washing Robo

- ✓ The Rice Washing Robo quickly and efficiently washes the rice.
- ✓ Each step is performed with the skill of a Japanese Sushi Chef.

Features

Storage-Type Rice Washing Robo

If a large volume of rice is stocked in preparation, this “all-in-one” model quickly and efficiently washes the required amount of rice and also automatically performs the adjustment to the optimal amount of water for the rice cooking (water adjust). This stable cooking makes it possible to offer delicious rice at any time.

- Securely stocks up to 60 kg of rice.
- Hygienically prevents the adverse effects of moisture to stocked rice.
- Efficiently and economically washes rice using only a minimal amount of water in a reduced amount of time.
- Features easy operation and reliable functions.
- The container stand can be adjusted to two different levels as required.
- A container sensor eliminates wasted rice.
- The washing method and water adjustment can be set to suit the application.
- Includes a reservation function

Models | **KP720NA-UL**
(Rice stock quantity: 60kg)



Specifications

Model	Kubota Rice Washing Robo
Type	KP720NA-UL
Maximum throughput (once)	6.0kg
Setting quantity of rice (one operation)	6.0kg, 5.5kg, 5.0kg, 4.5kg, 4.0kg, 3.5kg, 3.0kg
Rice washing time (Water discharge time is not included)	Approximately 2 minutes (6.0kg standard washed rice)
Maximum electric power consumption	120V 60Hz 1.0A
Rated inlet water pressure	42 ~ 50PSI
Dimensions (mm)	Width 540 × depth 645 × height 1756
Weight (kg)	60
Rice Stock Quantity(kg)	60

*Specifications as well as the external view may be changed to incorporate design changes without notification.

External view (mm)

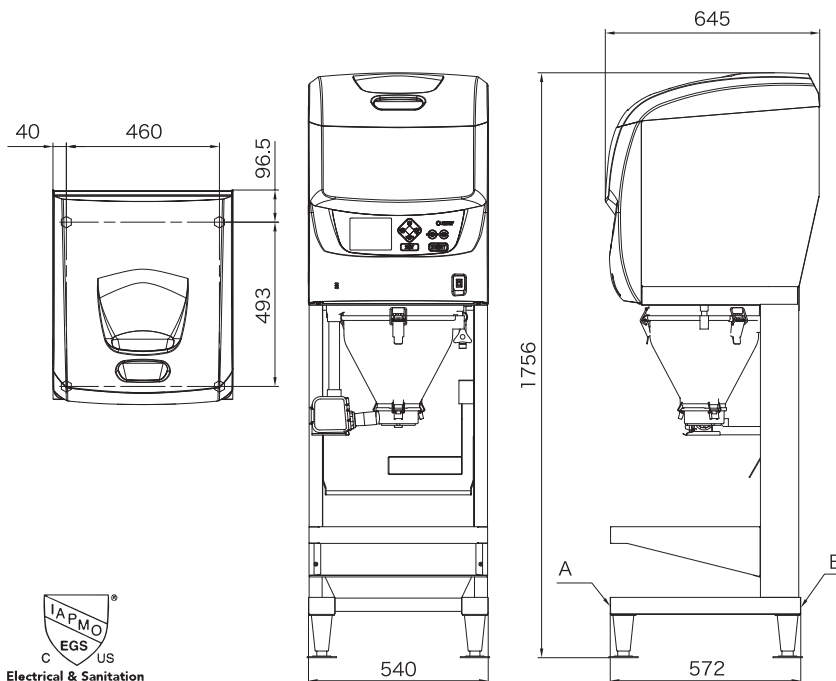

- Prior to using these products, carefully read the appropriate "Instruction Manual" regarding proper installation and operation. Faulty installation and handling is liable to result in accidents and/or injury.
- Installation should be performed by the vendor or its designated representative. Faulty installation is liable to cause accidents and/or injury. Further, when installation requires also installing gas or electricity, please contact the appropriate service personnel.

Other features

Unique "Double Multi-Jet Rice Washing Method"

Double Multi-Jet Shower Nozzles

Semi-sphere shaped, the double Multi-Jet Shower Nozzles efficiently, economically, and evenly wash rice in the Tank using only a relatively small quantity of water.

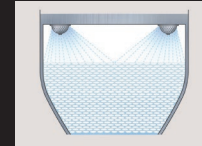

Multi-Angled Stirring Blade Reduces Rice Washing Time

The multi-angled design of the Stirring Blade ensures the rice is evenly stirred. The Bran – the hard outer layer of the grains of rice – is quickly and efficiently removed to contribute to efficient rice washing in a remarkably reduced amount of time.



*The multi-angled Stirring Blade (Rice Washing Tank not shown)

Simple and Easy-to-See Operation Paneltime

Simply turn the power "ON" and then press the Start Switch. Thereafter, the pre-set amount of rice is automatically loaded, the appropriate quantity of water is added for quick, efficient washing, and finally the washed rice is emptied into the appropriate container.



Kubota

KUBOTA CORPORATION

2-47, Shikitsu Higashi 1-chome, Naniwa-ku Osaka, 556-8601 Japan

Suzumo International Corporation

Head Office : 1815 W. 205th Street, Suite 101 Torrance, CA 90501 U.S.A.
Tel. +1 310-328-0400 Fax. +1 310-328-2700 e-mail sic@suzumokikou.com

East Office : 375 North Street, Unit K, Teterboro, NJ 07608 U.S.A.
Tel. +1 201-568-1900 e-mail sic@suzumokikou.com