

High Capacity Production in a Compact Machine
to Produce Various Shapes of Rice Products

Omusubi Making Machine **MOS-FMC**

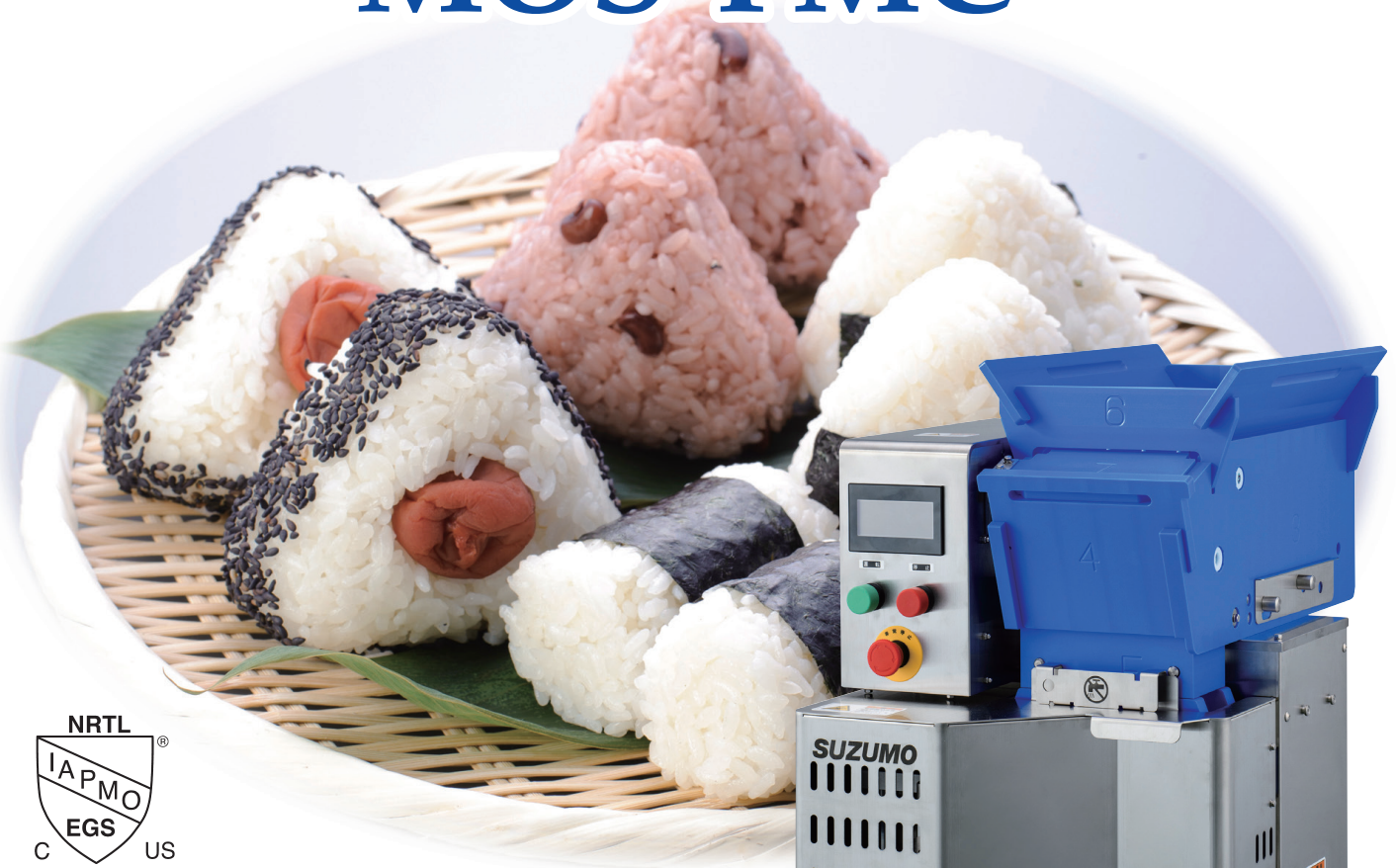

Production Capacity:
3600pcs./hr.
(40-80g)



Highly versatile machine that can produce a variety of rice products for Convenience Stores, Supermarkets, Quick Service Restaurants, and more.

- Accepts vacuum-cooled rice (20-25 °C with oil) and high-temperature rice
- Large hopper holds 10kg of cooked rice and is easy to replenish
- Greatly contributes to labor savings and production improvement

Dimensions

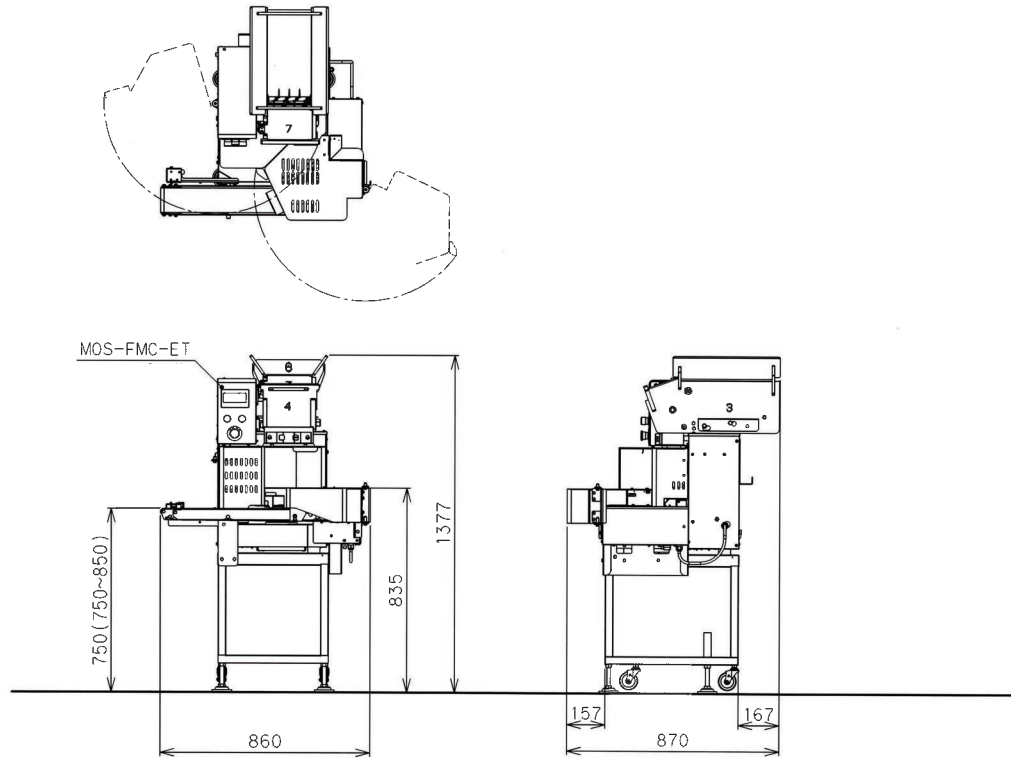

Specifications

Model	MOS-FMC-ET (Meets UL/NSF standards)
Production Capacity	40-80g Max. 3600 pcs/hr. 81-100g Max. 3300 pcs/hr. 101-120g Max. 3000 pcs/hr.
Machine Dimensions	480W×720D×805Hmm (Main Unit) 860W×870D×1370-1470Hmm (incl. Output Conveyor, Caster Stand)
Power / Frequency	AC110-120V, 50/60Hz
Power Consumption	240W (290W / with Output Conveyor, Caster Stand)
Hopper Capacity	Approx. 10kg
Weight per Piece	40g-120g
Mold Type	Round 74 (with or w/o Ingredient hole) Triangle 73 (with or w/o Ingredient hole, small hole) Triangle 62 (with or w/o Ingredient hole) Triangle 52 (with or w/o Ingredient hole) Tawara x 2 (35g x 2) Tawara (40g)
Machine Weight	Approx. 85kg

Top Features

- High production capacity equivalent to mass production in a clean compact machine.
- Produce fluffy and delicious Omusubi rice products easily using our unique rice loosening and precise rice measuring technology.
- Equipped with an LCD panel with Touch menu for easy viewing and operation.
- 12 custom settings of rice recipes can be stored into memory.
- Supports a wide range of product forms and sizes from 40-120g of cooked rice.
- Minimum number of food contact parts for safe production and easy cleaning.

* Designs and specifications are subject to change without notice. * Follow the instructions in the operation manual when handling the machine.
* Production capacity and capabilities are based on the machine when correctly operated.

Suzumo Machinery Co., Ltd. Global Business Division

2-23-2, Toyotamakita, Nerima-ku, Tokyo 176-0012, Japan
Tel. +81 3-3993-1407 Fax. +81 3-3993-1756
e-mail overseas@suzumo.co.jp URL <http://www.suzumokikou.com>

< Contact in North America >

Suzumo International Corporation

Head Office : 1815 W. 205th Street, Suite 101 Torrance, CA 90501 U.S.A.
Tel. +1 310-328-0400 Fax. +1 310-328-2700 e-mail sic@suzumokikou.com
East Office : 375 North Street, Unit K, Teterboro, NJ 07608 U.S.A.
Tel. +1 201-568-1900 e-mail sic@suzumokikou.com

< Contact in Singapore >

Suzumo Singapore Corporation Pte. Ltd.

421 Tagore Industrial Avenue #04-11 Tagore 8, Singapore 787805
Tel. +65 6254-2080 Fax. +65 6254 2086 e-mail sales@suzumo-sg.com

202308(suzumo)