

SIC



# Compact Cooked-Rice Mixer "SHARIKKA" MCR-SSC-ET



**Light weight  
durable resin drum**

Turn the most delicate aspect of sushi preparation, the blending of rice and vinegar, into an automatic process that yields perfect results.



# Compact Cooked-Rice Mixer "SHARIKKA" MCR-SSC-ET

## Features

- The compact design saves installation space, ideal for a small kitchen.
- Touch-panel screens enable easy operation.
- Blending method without pressure on rice enables to produce highest quality "shari" (sushi rice) just like experienced sushi chef's make.
- Three different pre-set blending programs are selectable, depending on the type and amount of rice.
- Rice can be cooled down to the appropriate temperature by a built-in blower during the blending process.
- Available for various applications; "Shari" blended with sushi vinegar, mixed rice with assorted mixtures, loosened rice in fluffier condition and etc.
- The "shari" or processed rice is easily discharged from the drum by a simple touch operation.
- Easy cleaning is possible as washable parts can be dismantled and reassembled without tools.
- Connectable to household electric outlets.

## Specifications

### Model

Sharikka MCR-SSC-ET (Meets UL/NSF standards)

### Power

AC120V, 60Hz Single phase

### Power consumption

95W

### External dimensions

496W×604D×872Hmm

\* The dimensions do not contain bumps and bosses.

### Rice Amount Capacity

Maximum 6.5kg of cooked rice

### Machine weight

Approx. 38kg

### Mechanism

Fully automatic

(Placing the rice and sushi vinegar into the drum is done manually.)

## Dimensions

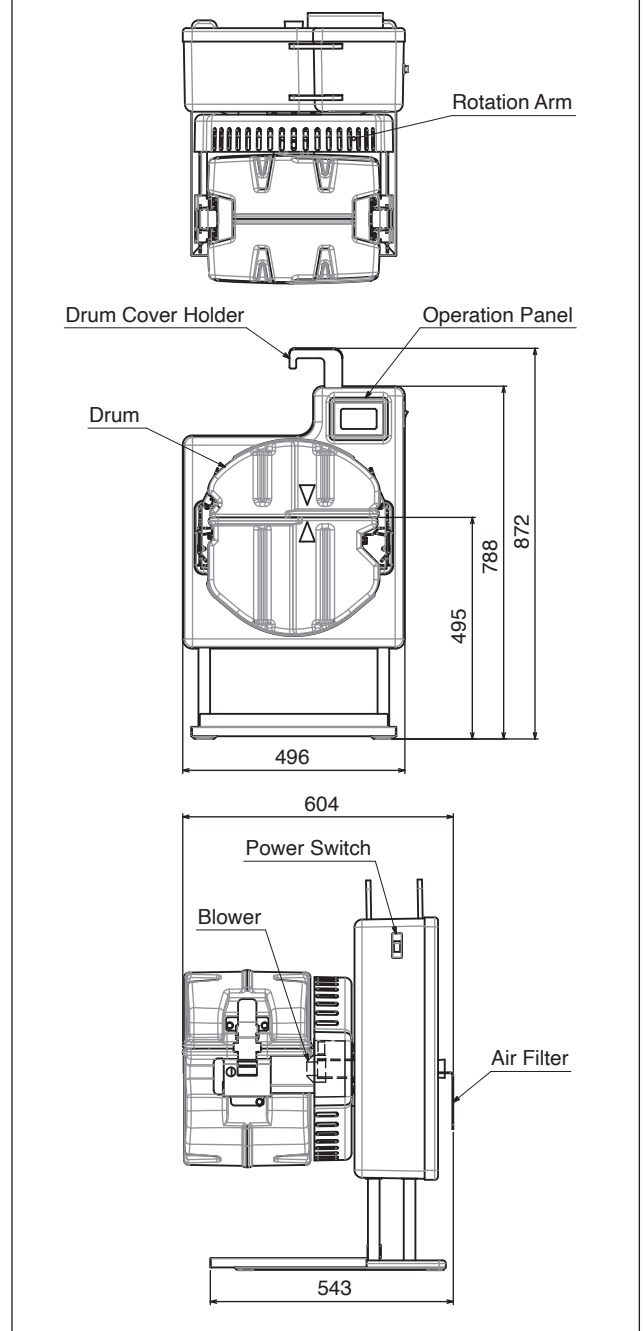

\* Designs and specifications subject to change without notice.

\* Please follow the directions in the operations manual when handling the machine.

\* While capacity expresses the machine's performance capabilities, it is predicated upon the machine being operated correctly.

## Suzumo Machinery Co., Ltd. Global Business Division

2-23-2, Toyotamakita, Nerima-ku, Tokyo 176-0012, Japan

Tel. +81 3-3993-1407 Fax. +81 3-3993-1756

e-mail overseas@suzumo.co.jp URL <http://www.suzumokikou.com>

< Contact in North America >

### Suzumo International Corporation

Head Office : 1815 W. 205th Street, Suite 101 Torrance, CA 90501 U.S.A.

Tel. +1 310-328-0400 Fax. +1 310-328-2700 e-mail sic@suzumokikou.com

East Office : 375 North Street, Unit K, Teterboro, NJ 07608 U.S.A.

Tel. +1 201-568-1900 e-mail sic@suzumokikou.com

< Contact in Singapore >

### Suzumo Singapore Corporation Pte. Ltd.

421 Tagore Industrial Avenue #04-11 Tagore 8, Singapore 787805

Tel. +65 6254-2080 Fax. +65 6254 2086 e-mail sales@suzumo-sg.com

202111(suzumo)