

SIC



Sushi rice mixing made easy!

The most delicate part of sushi rice preparation is blending the cooked rice with vinegar. This blender is made fully automated, making it simple while giving a perfect result.



- Light weight drum
- High grade non-stick parts
- Easy handling
- Easy cleaning
- 6 pre-programmed settings
- Auto dispensing feature



Cooked-Rice Mixer "SHARIKKA" MCR-ASB



Features

- Rice and vinegar are blended without damaging the rice grains like an experienced chef.
- Sushi rice is evenly cooled and mixed with simultaneous aeration and mixing.
- The sushi rice is poured out automatically when the mixing is complete.
- High grade non-stick resin eliminates Teflon coating.
- Drum parts (drum, lid, and agitator) can be taken apart in seconds for easy handling and cleaning.

Specification

Model

MCR-ASB-ET (Meets UL/NSF standards)
MCR-ASB-AS

Power

AC110-120V, 60Hz, Single phase (MCR-ASB-ET)
AC220-240V, 60Hz, Single phase (MCR-ASB-AS)

Power consumption

400W

Machine dimensions

Width 600mm (23.62in)
Depth 690mm (27.17in)
Height 1,130mm (44.49in) (MCR-ASB-ET)
Height 1,050mm (41.34in) (MCR-ASB-AS)

* The dimensions do not show small bumps and bosses.

Rice Amount Capacity

Maximum 13kg (28.66lb) of cooked rice

Function

Fully Automated
(Rice and vinegar added manually.)

Mixing Time

Approx. 5-7minutes including auto dispensing time.

Machine Weight

Approx. 80kg (176.4lb)

Dimensions

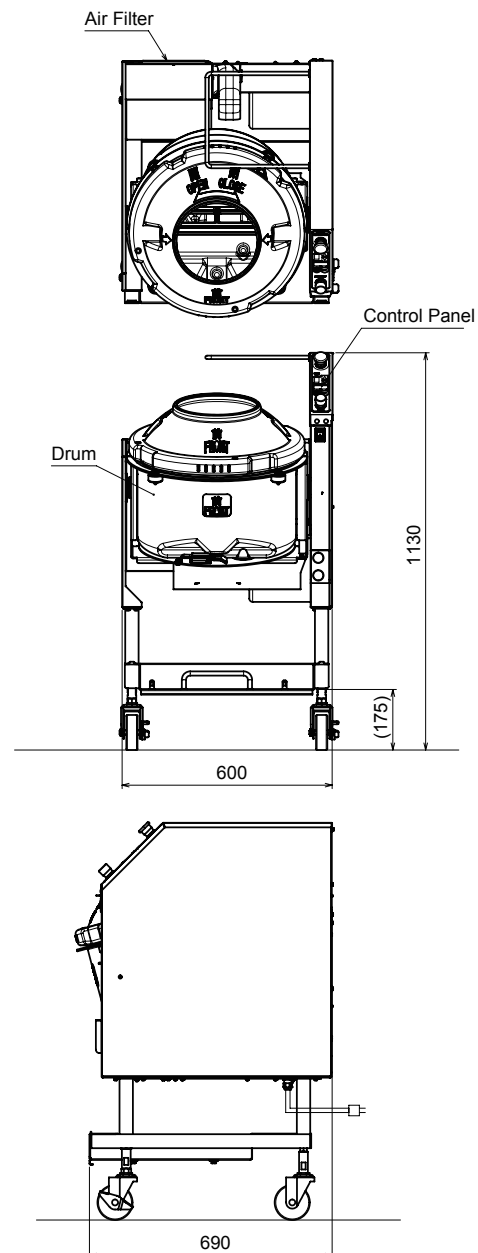

*The above drawing is made based on model MCR-ASB-ET. (mm)

*Designs and specifications are subject to change without notice. *Rice Amount Capacity described in Specification is based upon proper operation.

Suzumo Machinery Co., Ltd. Global Business Division

2-23-2, Toyotamakita, Nerima-ku, Tokyo 176-0012, Japan
Tel. +81 3-3993-1407 Fax. +81 3-3993-1756
e-mail overseas@suzumo.co.jp URL http://www.suzumokikou.com

< Contact in North America >

Suzumo International Corporation

Head Office : 1815 W. 205th Street, Suite 101 Torrance, CA 90501 U.S.A.
Tel. +1 310-328-0400 Fax. +1 310-328-2700 e-mail sic@suzumokikou.com

East Office : 375 North Street, Unit K, Teterboro, NJ 07608 U.S.A.
Tel. +1 201-568-1900 e-mail sic@suzumokikou.com

< Contact in Singapore >

Suzumo Singapore Corporation Pte. Ltd.

421 Tagore Industrial Avenue #04-11 Tagore 8, Singapore 787805
Tel. +65 6254-2080 Fax. +65 6254 2086 e-mail sales@suzumo-sg.com